

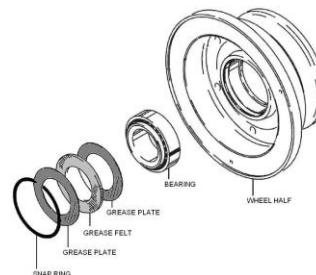

McFarlane Aviation Products

New! FAA-PMA approved Grease Felts and Retaining Rings for Cleveland & McCauley Wheels!



McFarlane now has FAA-PMA approval for grease felts and retaining rings. Current approvals are for Cessna models thru C177. Approvals for the remaining single-engine Cessna models and Cessna twins thru the 400 series are pending FAA approval. Future approvals will include Air Tractor, Beechcraft, Bellanca, Cessna, Cirrus, Diamond, Mooney, Piper and more!

Part numbers currently available are Grease Felt part numbers MC154-00300, MC154-00600, MC154-00900, MC154-01300 and MC154-30010. Retaining Ring part numbers available are MC155-00100, NC155-00200, MC155-11800 and MC155-11900.

New! Torque Link Stop Lug and Safety Plate for Cessna Aircraft FAA-PMA Approved - High Demand Part

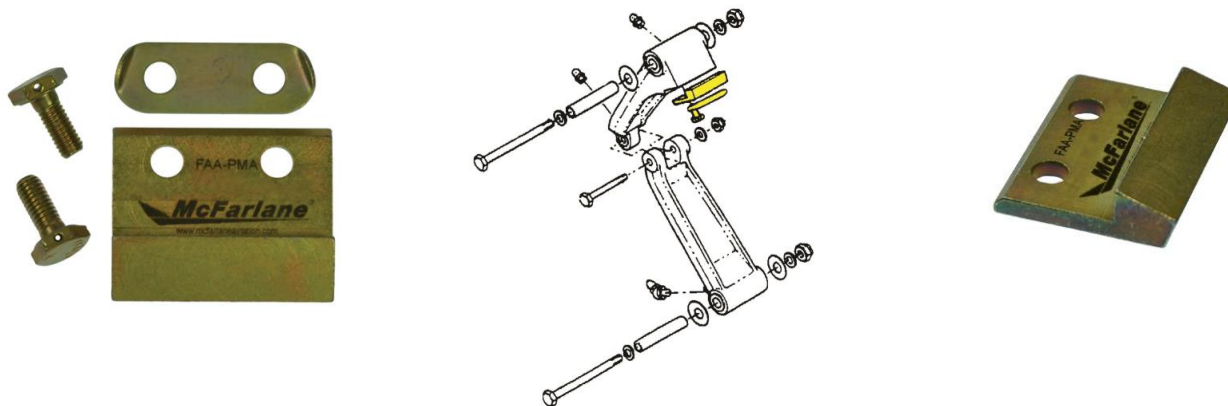

Now available and in high demand, the McFarlane Torque Link Stop Lugs and Safety Plate for Cessna single engine aircraft are ready for immediate shipment. The stop lug is an often overlooked, but important part, and is now affordable"

The stop lug is a critical part for maintaining nose wheel alignment after takeoff and preventing over extension of the nose strut. The safety plate prevents the bolts securing the stop lug from loosening and must be replaced when replacing the stop lug. Both parts can be purchased separately or as a convenient kit, including applicable 3/16" bolts. Cessna owners have been requesting this part for some time and McFarlane has answered the call.

- Direct OEM Replacement
- Available as Individual Parts or as a Convenient Kit
- Great Value on an Important Part

*[can be found] the
McFarlane Catalog c our website:*



WWW.GOULETAIRCRAFT.COM